



Automated Environmental Systems



# POOL HEAT PUMP *MANUAL*

## Remora Professional Inverter Swimming Pool Heat Pump





## TABLE OF CONTENT

1. PREFACE .....	2
2. CARTON CONTENTS .....	5
3. OVERVIEW OF THE UNIT .....	6
4. INSTALLATION AND CONNECTION .....	8
4.1 Installation Illustration .....	8
4.2 Swimming Pool Heat Pumps Location .....	8
4.3 How Close to Your Pool? .....	9
4.4 Swimming Pool Heat Pumps Plumbing .....	9
4.5 Swimming Pool Heat Pumps Electrical Wiring .....	10
4.6 Initial Startup of the Unit .....	10
5. OPERATING THE UNIT .....	11
6. LCD CONTROLLER .....	12
6.1 LCD CONTROLLER INTERFACE .....	12
6.2 KEYPAD LOCK / UNLOCK .....	14
6.3 MAIN RUNNING MODE SELECTION .....	14
6.4 SUB-RUNNING MODE SELECTION .....	14
6.5 SETTING THE TIMER .....	15
6.6 PARAMTER SETTING .....	16
6.7 RUNNING STATUS QUERY .....	18
6.8 CHECK POWER CONSUMPTION .....	21
6.9 FAULT HISTORY .....	21
6.10 VACATION SETTING .....	22
6.11 TIMER SET FOR SILENT MODE .....	23
6.12 HELP .....	23
7. ERROR CODES .....	24
8. MAINTENANCE AND INSPECTION .....	28
9. WIRING DIAGRAMS .....	34
10. CABLE SPECIFICATION .....	36
11. WIFI / APP APPLICATION .....	37



READ THIS MANUAL CAREFULLY BEFORE OPERATING THE UNIT. DO NOT THROW IT AWAY.  
RETAIN FOR FUTURE REFERENCE.



BEFORE OPERATING THE UNIT, ENSURE THE INSTALLATION HAS BEEN CARRIED OUT IN ACCORDANCE  
WITH THESE INSTRUCTIONS. IF IN DOUBT PLEASE CONSULT YOUR LOCAL DEALER.

## 1. PREFACE

- ✧ In order to provide our customers with quality, reliability and versatility, this product has been made to strict production standards.

This manual includes all the necessary information about installation, debugging, discharging and maintenance. Please read this manual carefully before you open or maintain the unit.

The manufacture of this product will not be held responsible if someone is injured or the unit is damaged, as a result of improper installation, debugging, or unnecessary maintenance. It is vital that the instructions within this manual are adhered to at all times. The unit must be installed by qualified personnel.

- ✧ The unit can only be repaired by qualified installer centre , personnel or an authorized dealer.
- ✧ Maintenance and operation must be carried out according to the recommended time and frequency, as stated in this manual.
- ✧ Use genuine standard spare parts only.  
Failure to comply with these recommendations will invalidate the warranty.
- ✧ Swimming Pool Heat Pump Unit heats the swimming pool water and keeps the temperature constant. For split type unit, The indoor unit can be Discretely hidden or semi-hidden to suit a luxury house. Our heat pump has following characteristics:

a. Durable

The heat exchanger is made of PVC & Titanium tube which can withstand prolonged exposure to swimming pool water.

b. Installation flexibility

The unit can be installed outdoors.

c. Quiet operation

The unit comprises an efficient rotary/ scroll compressor and a low-noise fan motor, which guarantees its quiet operation.

d. Advanced controlling

The unit includes micro-computer controlling, allowing all operation parameters to be set. Operation status can be displayed on the LCD wire controller. Remote controller can be chosen as future option.

## WARNING

Do not use means to accelerate the defrosting process to clean, other than those recommended by the manufacturer.



The appliance shall be stored in a room without continuously operating ignition sources (for example: open flames, an operating gas appliance or an operating electric heater.)

Do not pierce or burn.

Be aware that refrigerants may not contain an odour.

**NOTE:** The manufacturer may provide other suitable examples or may provide additional information about the refrigerant odour.

- ✧ This appliance can be used by children aged from 8 years and above and persons with reduced physical, sensory or mental capabilities or lack of experience and knowledge if they have been given supervision or instruction concerning use of the appliance in a safe way and understand the hazards involved. Children shall not play with the appliance. Cleaning and user maintenance shall not be made by children without supervision.
- ✧ If the supply cord is damaged, it must be replaced by the manufacturer, its service agent or similarly qualified persons in order to avoid a hazard.
- ✧ The appliance shall be installed in accordance with national wiring regulations.
- ✧ Before obtaining access to terminals, all supply circuits must be disconnected.
- ✧ Spaces where refrigerant pipes shall be compliance with national gas regulations. Servicing shall be performed only as recommended by the manufacturer. The appliance shall be stored in a well-ventilated area. All working procedure that affets safety means shall only be carried by competent persons.
- ✧ Transport of equipment containing flammable refrigerants  
Compliance with the transport regulations  
Marking of equipment using signs  
Compliance with local regulations
- ✧ Disposal of equipment using flammable refrigerants  
Compliance with national regulations
- ✧ Storage of equipment/appliances  
The storage of equipment should be in accordance with the manufacturer's instructions.
- ✧ Storage of packed (unsold) equipment  
Storage package protection should be constructed such that mechanical damage to the equipment inside the package will not cause a leak of the refrigerant charge. The maximum number of pieces of equipment permitted to be stored together will be determined by local regulations.

## Caution & Warning

1. Please make sure that the unit and power connection have good earthing, otherwise may cause electrical shock.

2. Directive 2002/96/EC (WEEE):



The symbol depicting a crossed-out waste bin that is underneath the appliance indicates that this product, at the end of its useful life, must be handled separately from domestic waste, must be taken to a recycling centre for electric and electronic devices or handed back to the dealer when purchasing an equivalent appliance.

3. Directive 2002/95/EC (RoHs): This product is compliant with directive 2002/95/EC (RoHs) concerning restrictions for the use of harmful substances in electric and electronic devices.
4. The unit CANNOT be installed near the flammable gas. Once there is any leakage of the gas, fire can occur.
5. Make sure that there is circuit breaker for the unit, lack of circuit breaker can lead to electrical shock or fire.
6. The heat pump is equipped with an over-load protection system. It does not allow for the unit to start for at least 3 minutes from a previous stoppage.
7. Installation must be performed in accordance with local regulations by authorized person only.
8. USE SUPPLY WIRES SUITABLE FOR 75°C .
9. Caution: Single wall heat exchanger, not suitable for potable water connection.

## 2. CARTON CONTENTS

Before starting the installation, please make sure that all following items are found inside the box.

Carton Box		
Item	Image	Quantity
Swimming pool heat pump		1
Operation and Installation Manual		1
Accessories		1 (Set)

### 3. OVERVIEW OF THE UNIT

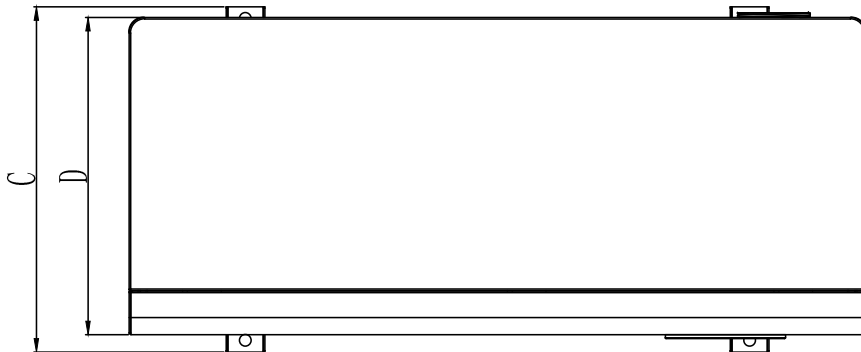
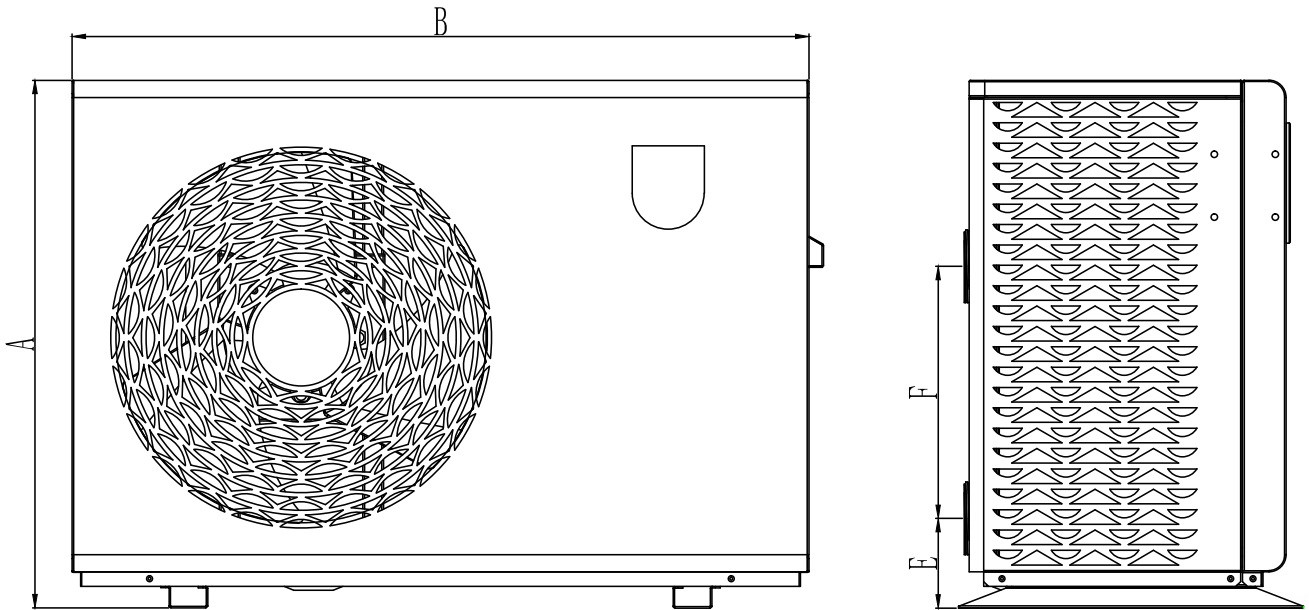

Key	Remora Professional 8 Remora Professional 10 Remora Professional 14	Remora Professional 19 Remora Professional 25
A	653	715
B	870	1020
C	380	408
D	351	367
E	96	87
F	325	395



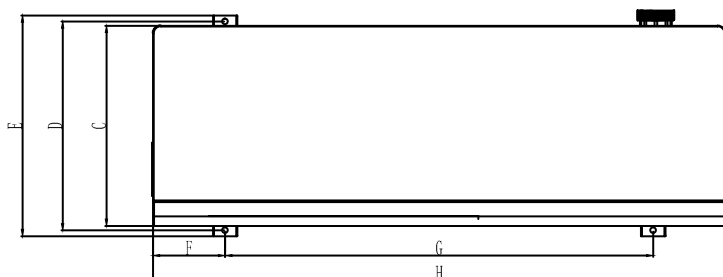
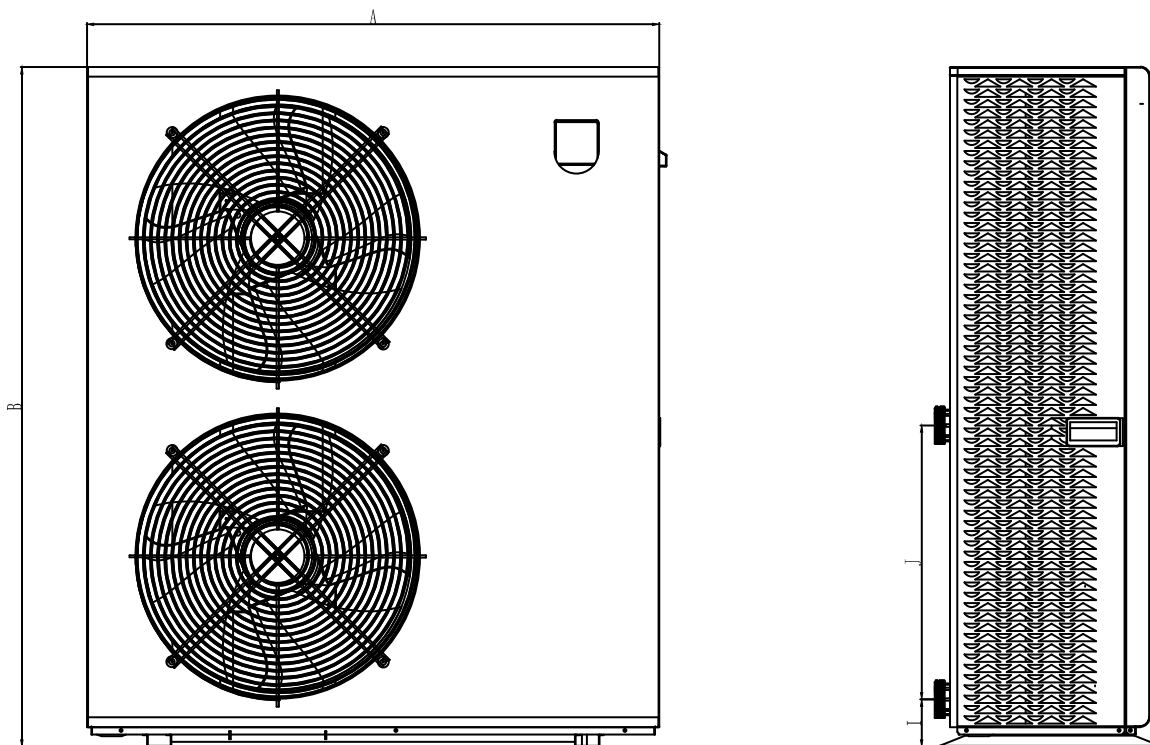

Key	Remora Professional 35		
A	1170	F	148
B	1389	G	875
C	409	H	1170
D	427	I	97
E	451	J	560

## 4. INSTALLATION AND CONNECTION

### 4.1 Installation Illustration

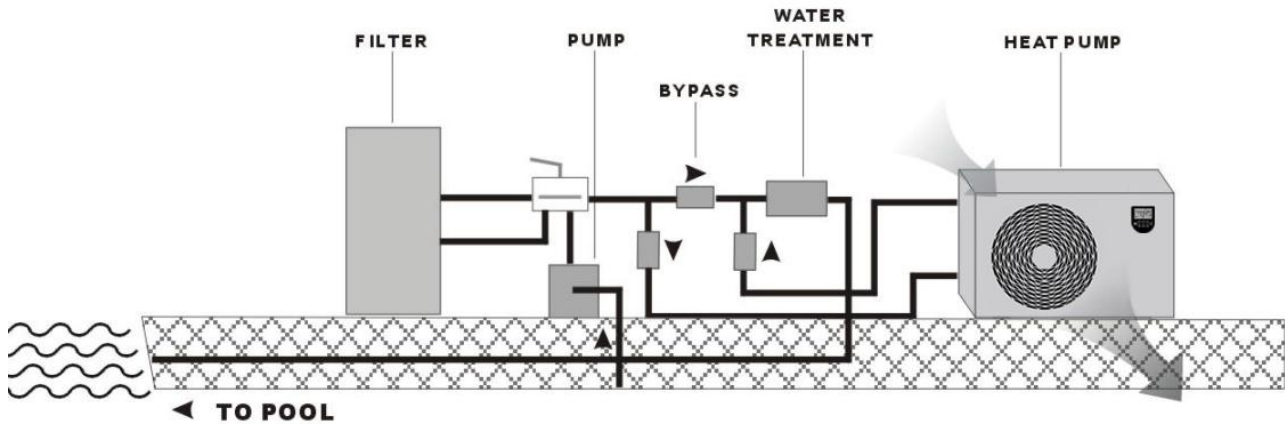

#### Installation items:

The factory only provides the main unit, the other items in the illustration are necessary spare parts for the water system, that provided by users or the installer.

#### Attention:

Please follow these steps when using for the first time

1. Open valve and charge water.
2. Make sure that the pump and the water-in pipe have been filled with water.
3. Close the valve and start the unit.

**NOTES:** It is necessary that the water-in pipe is higher than the pool surface.

The schematic diagram is for reference only. Please check the water inlet/outlet label on the heat pump while plumbing installation.

The controller could be mounted on the wall.

### 4.2 Swimming Pool Heat Pumps Location

The unit will perform well in any outdoor location provided that the following three factors are presented:

1. Fresh Air - 2. Electricity - 3. Pool filter piping

The unit may be installed virtually anywhere outdoors. For indoor pools please consult the supplier. Unlike a gas heater, it has no draft or pilot light problem in a windy area.

DO NOT place the unit in an enclosed area with a limited air volume, where the units discharge air will be re-circulated.

DO NOT place the unit to shrubs which can block air inlet. These locations deny the unit of a continuous source of fresh air which reduces its efficiency and may prevent adequate heat delivery.

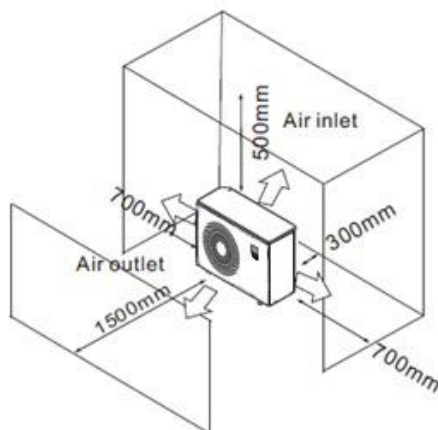

#### 4.3 How Close To Your Pool?

Normally, the pool heat pump is installed within 7.5 metres of the pool. The longer the distance from the pool, the greater the heat loss from the piping.

#### 4.4 Swimming Pool Heat Pumps Plumbing

The Swimming Pool Heat Pumps exclusive rated flow titanium heat exchanger requires no special plumbing arrangements except bypass. Since there is no residual heat or flame temperatures, the unit does not need copper heat sink piping. PVC pipe can be run straight into the unit.

Location: Connect the unit in the pool pump discharge (return) line downstream of all filter and pool pumps, and upstream of any chlorinators, ozonators or chemical pumps.

Standard models have fittings which accept 32mm or 50 mm PVC pipe for connection to the pool or spa filtration piping.

Give serious consideration to adding a quick coupler fitting at the unit inlet and outlet to allow easy draining of unit for winterizing and to provide easier access that should servicing be required.

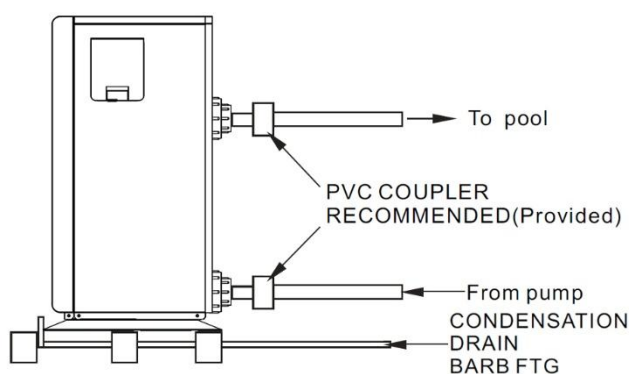



## WARNING

- PLEASE USE ORIGINAL UNION FITTINGS IN THE CARTON.
- PLEASE CHECK IF RUBBER O-RING INSTALLED ON THE CONNECTORS OR NOT.
- PLEASE DON'T USE TAPE OR GLUE FOR CONNECTION.
- PLEASE HAND TIGHTEN THE CONNECTORS ONLY.

Condensation: Since the Heat pump cools down the air about 4 -5 , water may condense on the fins of the horseshoe shaped evaporator. If the relative humidity is very high, this could be as much as several litres an hour. The water will run down the fins into the basepan and drain out through the barbed plastic condensation drain fitting on the side of the basepan. This fitting is designed to accept 20mm clear vinyl tubing which can be pushed on by hand and run to a suitable drain. It is easy to mistake the condensation for a water leak inside the unit.

NB: A quick way to verify that the water is condensation is to shut off the unit and keep the pool pump running. If the water stops running out of the basepan, it is condensation. AN EVEN QUICKER WAY IS to TEST THE DRAIN WATER FOR CHLORINE - if there is no chlorine present, then it's condensation.

#### 4.5 Swimming Pool Heat Pumps Electrical Wiring

NOTE: Although the unit heat exchanger is electrically isolated from the rest of the unit, it simply prevents the flow of electricity to or from the pool water. Grounding the unit is still required to protect you against short circuits inside the unit.

#### 4.6 Initial startup of the Unit

NOTE: In order for the unit to heat the pool or spa, the filter pump must be running to circulate water through the heat exchanger.



Start up Procedure - After installation is completed, you should follow these steps:

1. Turn on your filter pump. Check for water leaks and verify flow to and from the pool.
2. Turn on the electrical power supply to the unit, then press the key ON/OFF of wired controller, It should start in several seconds.
3. After running a few minutes make sure the air leaving the top (side) of the unit is cooler (Between 5 ~ 10°C )
4. With the unit operating turn the filter pump off. The unit should also turn off automatically.

Time Delay- The unit is equipped with a 3 minute built-in solid state restart delay included to protect control circuit components and to eliminate restart cycling and contactor chatter. This time delay will automatically restart the unit approximately 3 minutes after each control circuit interruption.

## 5. OPERATING THE UNIT

*This is achieved via the Digital Controller.*

-  NEVER LET THE DIGITAL CONTROLLER GET WET. THIS MAY CAUSE AN ELECTRIC SHOCK OR FIRE.
-  NEVER PRESS THE BUTTONS OF THE DIGITAL CONTROLLER WITH A HARD, POINTED OBJECT. THIS MAY DAMAGE THE DIGITAL CONTROLLER.
-  NEVER INSPECT OR SERVICE THE DIGITAL CONTROLLER YOURSELF. REFER TO A QUALIFIED SERVICE ENGINEER.

### Features and functions

#### Basic controller functions









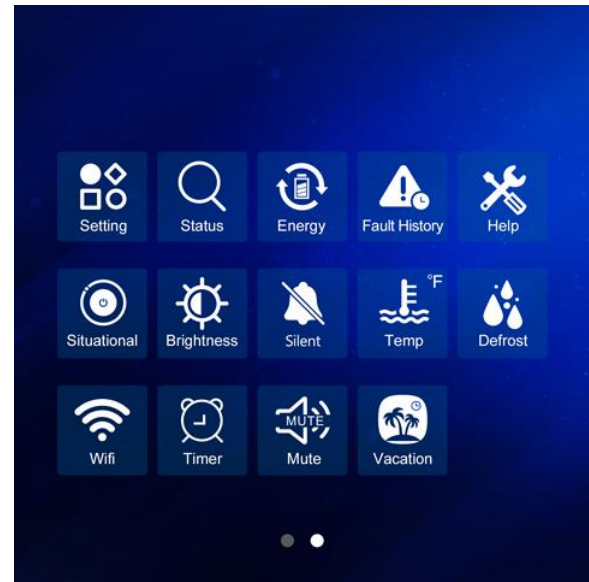

The basic controller functions are:











- Turning the heat pump 'ON'/'OFF'.
- 24 hour time clock.
- Timer 'ON' and Timer 'OFF'.
- Parameter adjustment.

## 6. LCD CONTROLLER

### 6.1 Control Panel Interface



Icon	Name	Function
	Anti-freeze	This icon will show if heat pump goes into Anti-freeze mode, and it will show in Grey once Anti-freeze exits.
	Defrost	This icon will show if heat pump goes into Defrost mode, and it will show in Grey once Defrost exists.
	Help	This icon will show if heat pump has failure.
	Timer Set for Silent Mode	This icon will show accordingly When press  to activate and set Timer for Silent Mode. (Unit will run Silent Mode within this Timer Set.)
	Timer	This icon will show if set the Timer successfully, and it will show in Grey if there is none Timer set.
	Vacation mode	This icon will show when the Vacation Mode Settings are valid.
	Key tone ON/OFF	This icon will show if turn key tone off by operating this button in 2nd page.
	WiFi connection	This icon will show if WiFi connection is activated, and it will show in Grey if WiFi connection is lost.
	External control	This icon will show if connect external control successfully, and it will show in Grey if External control is deactivated.

Icon	Name	Function
	Main running mode selection	This icon will indicate the actual main running mode of the unit. (Heating/ Cooling/ Auto modes for options).
Boost	Sub-running mode selection	This icon will indicate the actual sub-running mode of the unit. (Boost/ Silent/ Eco/ Smart sub-modes for options).
Set 27	Target water temperature	To show what's the target water temperature set.
Inlet 22.7	Inlet water temperature (or Error Code)	To show inlet water temperature or Error Code here.
Ambient 28.9	Ambient temperature	Ambient temperature (or Error code) will show under this this icon.
Outlet 23.0	Outlet water temperature	To show outlet water temperature.
	Keypad lock	It indicates the keypad is locked, press it to unlock the keypad.
	ON/OFF	Turn Unit ON or OFF.
	Setting	Press this button to enter into Function Menu, which includes: Status Query, Parameter Setting, Vacation Setting, Run Log, WIFI Reset, Historical Fault, Help.
	Status	Check unit running status.
	Energy	Check power consumption.
	Fault History	Check what failures have happened.
	Situational	Select unit Sub-running modes.
	Brightness	Adjust controller display brightness.
	Celsius and Fahrenheit display switching	To switch Celsius and Fahrenheit display.

## 6.2 Keypad Lock / Unlock



Indicates the keypad is unlocked, press it to lock the keypad.



Indicates the keypad is locked, press it to unlock the keypad.

## 6.3 Main Running Mode Selection

On the main operation interface, press the place at  to enter into main running mode selection and set target water temperature.





Press the place at  to choose Main Running Modes and set Target Water Temperatures.

Press **“OK”** to confirm.

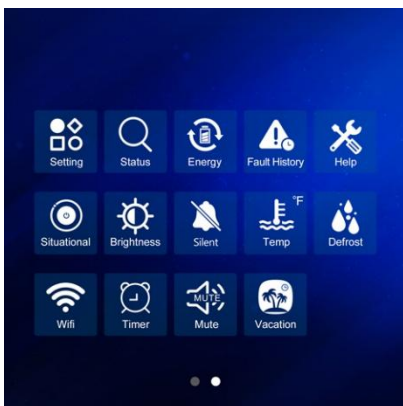

## 6.4 Sub-running Mode Selection



Press  to enter Into Sub-running Mode Selection.

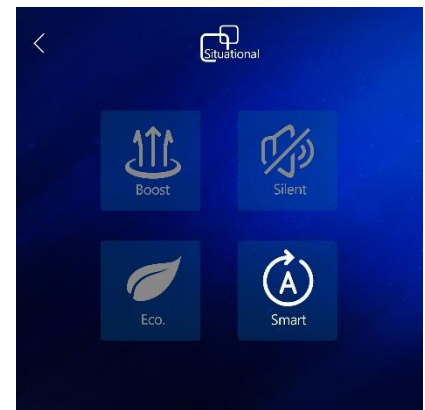



## 6.5 Setting the Timer

On the second page of main operation interface, press  to enter into Timer setting interface.

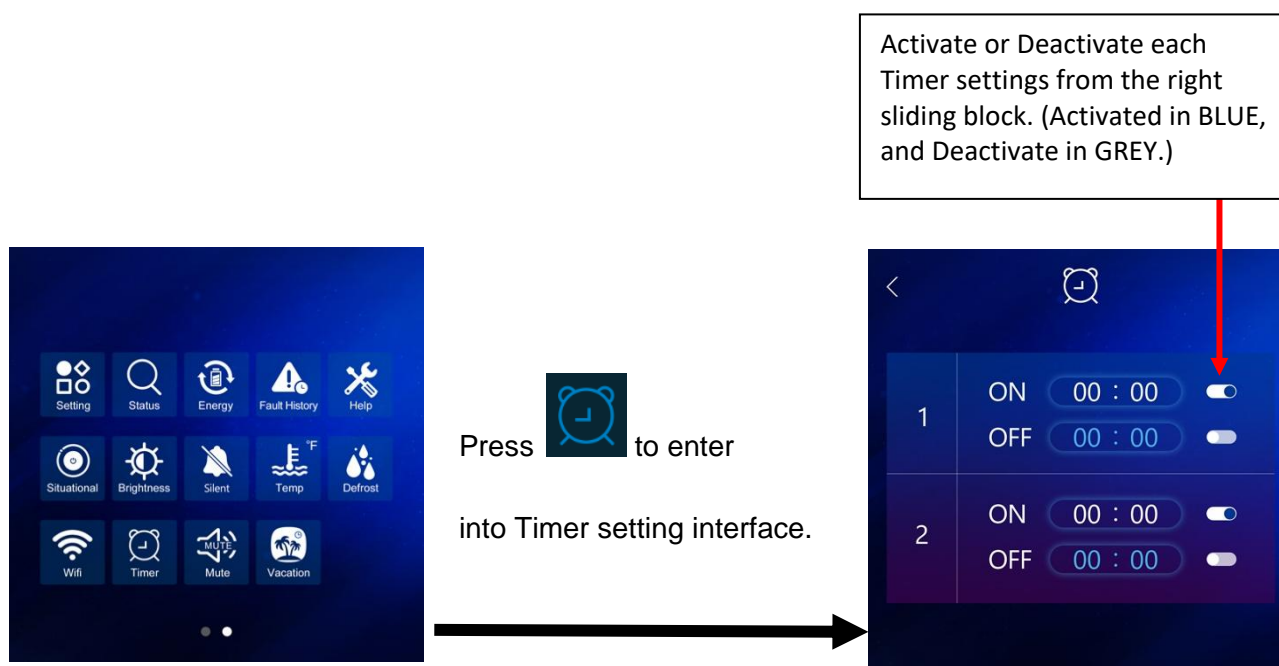

## 6.6 Parameter Setting



Press  to enter  
into Parameter Settings.

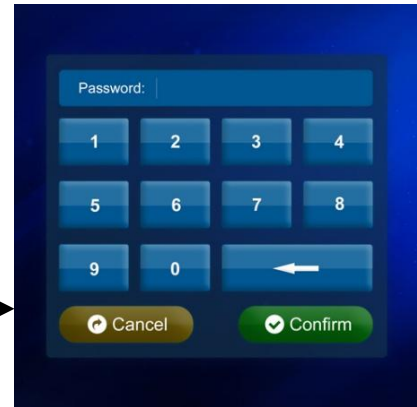

Input Password: **223344**  
to enter to set Parameter  
values.

**Level 1 Parameter Setting**

Code	Parameter Name	Set Value
P1	Cool mode water temp differential to restart	
P2	Heat mode water temp differential to restart	
P3	Main water pump P1P5 mode	
P4	Water pump running time in standby mode	
P5	Water pump stopping time in standby mode	
P6	TA temp display deviation	
P7	Cool mode valid or not	
P8	E-heater H1 valid or not	



Code	Parameter Name	Default	Range
P1	Cool mode water temperature differential to restart	1	1~10
P2	Heat mode water temperature differential to restart	1	1~10
P3	Main water pump P1P5 mode	2	0、 1、 2
P4	Water pump running time in standby mode	2	1~30
P5	Water pump stopping time in standby mode	180	3~240
P6	TA temp display deviation	0	-3~3
P7	Cool mode valid or not	1	0、 1
P8	Electric heater H1 valid or not	0	0、 1

## 6.7 Running Status Query



Press  to enter into status query.

Press  to navigate different pages.



No.	Parameter Name	Value or Status
1	Compressor frequency	Actual value
2	Fan speed	Actual value
3	EXV1 opening angle	Actual value
4	EXV3 opening angle	Actual value
5	TP compressor exhaust gas temp	Actual value
6	T3 coil temp	Actual value
7	T4 ambient temp	Actual value
8	TL liquid coil temp	Actual value
9	TJ EVI PHE outlet temp	Actual value
10	TJ2 EVI PHE inlet temp	Actual value
11	TH compressor suction gas temp	Actual value
12	TA inlet water temp	Actual value
13	TB outlet water temp	Actual value
14	Inverter module temp	Actual value
15	Required capacity	Actual value
16	Actual operating capacity after revision	Actual value
17	Inverter compressor current	Actual value
18	Voltage	Actual value
19	Model	
20	4-way valve status	ON; OFF

21	Main water pump P1	ON; OFF
22	SV1 by-pass valve status	ON; OFF
23	Inverter compressor heat belt HT1	ON; OFF
24	Chassis heat belt HT2	ON; OFF
25	Electric heater H1	ON; OFF
26	High pressure switch	ON; OFF
27	Low pressure switch	ON; OFF
28	Flow switch FS	ON ; OFF
29	External control Pump signal status	ON; OFF
30	External control signal status	ON; OFF
31	LCD Software version	

## 6.8 Check Power Consumption



Press “  ”



on the screen to find out running time and how much electricity consumption (kW.h) in every mode.



## 6.9 Fault History



Press “  ”

on the screen. Press  and  to navigate different pages.



## 6.10 Vacation Setting

HERE turn ON or OFF the “**Vacation Setting**” on the screen below.



Press  to enter into Vacation Setting.

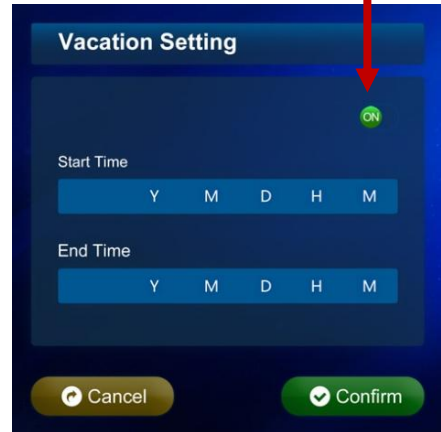

Press the line under “**Start Time**”.

Press the line under “**End Time**”.

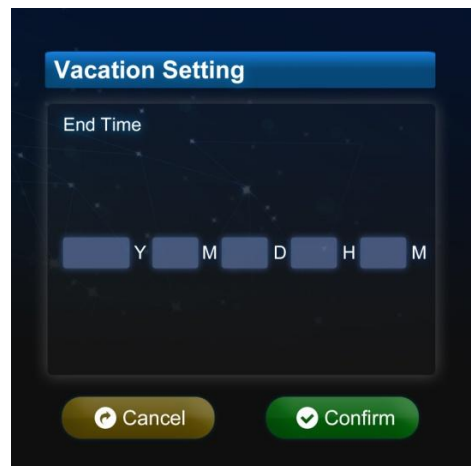
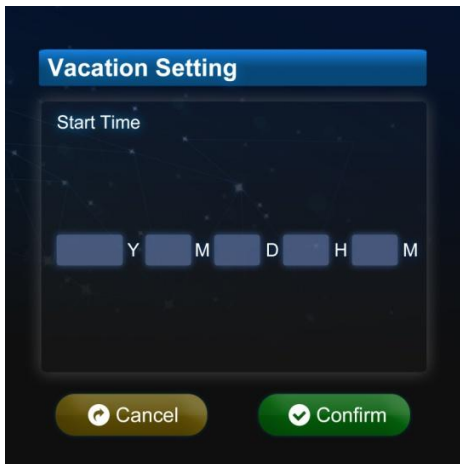



## 6.11 Timer Set for Silent Mode

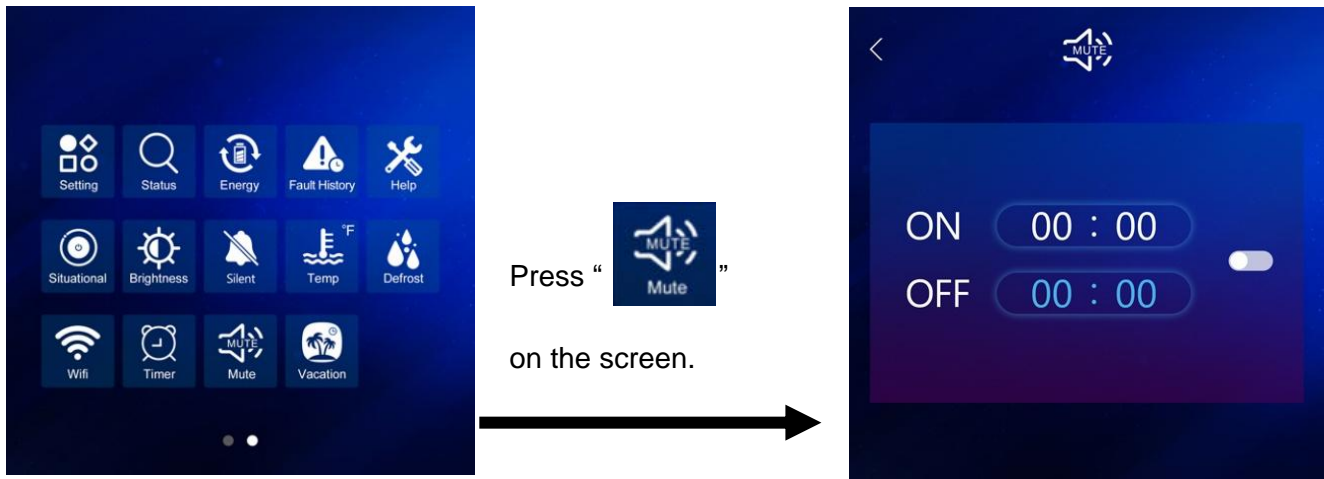

## 6.12 Help

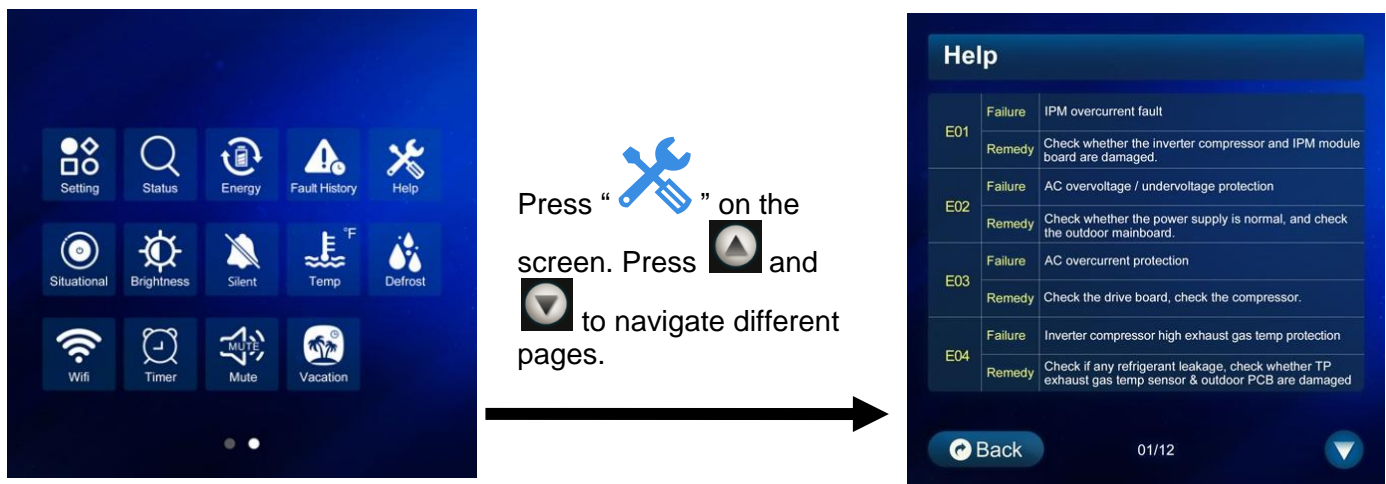

## 7. ERROR CODES

Error Code	Failure	Heat Pump Action	Remedy
<b>E01</b>	IPM overcurrent fault	System shutdown, fault reported	Check whether the inverter compressor and IPM module board are damaged.
<b>E02</b>	AC overvoltage / undervoltage protection	System shutdown, fault reported	Check whether the power supply is normal, and check the outdoor mainboard.
<b>E03</b>	AC overcurrent protection	System shutdown, fault reported	Check the drive board, check the compressor.
<b>E04</b>	Inverter compressor high exhaust gas temp protection	System shutdown, fault reported	Check if any refrigerant leakage, check whether TP exhaust gas temp sensor & outdoor PCB are damaged.
<b>E05</b>	Cool mode condenser high temp protection	System shutdown, fault reported	Check fan, EXV2, T3 coil temp sensor, outdoor PCB.
<b>E06</b>	Inverter compressor current protection	System shutdown, fault reported	Check inverter compressor, check outdoor PCB module.
<b>E07</b>	T4 ambient temp sensor failure	System shutdown, fault reported	Check ambient temp sensor and outdoor PCB.
<b>E08</b>	T3 coil temp sensor failure	System shutdown, fault reported	Check T3 coil temp sensor and outdoor PCB.
<b>E09</b>	TP exhaust gas temp sensor failure	System shutdown, fault reported	Check TP1 exhaust gas temp sensor and outdoor PCB.
<b>E10</b>	The DC bus voltage is too low or too high.	System shutdown, fault reported	Check drive board.
<b>E11</b>	Current detection circuit failure	System shutdown, fault reported	Check the outdoor mainboard.
<b>E12</b>	Drive board communication failure	System shutdown, fault reported	Check drive board.

<b>E13</b>	Fan failure	System shutdown, fault reported	Check whether the fan motor and outdoor PCB are damaged.
<b>E14</b>	TH suction gas temp sensor failure	System shutdown, fault reported	Check TH suction gas temp sensor and outdoor PCB.
<b>E15</b>	Driver EE failure	System shutdown, fault reported	Check drive board.
<b>E16</b>	Indoor unit PCB EE failure	System shutdown, fault reported	Check indoor unit PCB.
<b>E17</b>	Low pressure switch failure	System shutdown, fault reported	Check low pressure switch, and outdoor PCB.
<b>E18</b>	High pressure switch 1 failure	The fault is detected only when the compressor shuts down and reported as a fault.	Check high pressure switch 1, and outdoor PCB.
<b>E19</b>	High IPM module temperature	System shutdown, fault reported	Check drive board.
<b>E20</b>	Instant power failure	System shutdown, fault reported	Check drive board.
<b>E22</b>	TJ2 economizer inlet sensor failure	System shutdown, fault reported	Check TJ2 inlet temp sensor and outdoor PCB.
<b>E23</b>	TJ economizer outlet sensor failure	System shutdown, fault reported	Check TJ outlet temp sensor and outdoor PCB.
<b>E24</b>	TA inlet water temp sensor failure	System shutdown, fault reported	Check TA inlet water temp sensor and outdoor PCB.
<b>E25</b>	TB plate heat exchanger outlet water temp sensor failure	System shutdown, fault reported	Check TB plate heat exchanger outlet water temp sensor and outdoor PCB.
<b>E26</b>	Flow switch FS1 protection (Outdoor unit)	System shutdown, fault reported	Check water pump, flow switch 1 and outdoor PCB.
<b>E27</b>	Low water flow protection	System shutdown, fault reported	Check water pump and outdoor PCB.

<b>E28</b>	High outlet water temp protection in heat mode	System shutdown, fault reported	Check water pump and outdoor PCB.
<b>E29</b>	Low outlet water temp protection in cool mode	System shutdown, fault reported	Check water pump and outdoor PCB.
<b>E30</b>	TL Liquid coil temp sensor failure	System shutdown, fault reported	Check TL liquid coil temp sensor and outdoor PCB.
<b>E31</b>	The evaporator TL temperature is too low during operation	System shutdown, fault reported	Check TL liquid coil temp sensor and outdoor PCB.
<b>E32</b>	LCD controller communication failure	System shutdown, fault reported	Check whether the communication line is connected correctly. Check whether indoor PCB and LCD controller are damaged.
<b>E33</b>	Abnormal PFC	System shutdown, fault reported	Check drive board.
<b>E34</b>	PFC current protection	System shutdown, fault reported	Check inverter compressor and outdoor PCB & module board.
<b>E35</b>	Out of step	System shutdown, fault reported	Check the drive board, and compressor.
<b>E36</b>	Compressor phase loss	System shutdown, fault reported	Check the drive board, compressor, and connection line.
<b>E37</b>	Compressor startup failure	System shutdown, fault reported	Check the drive board, and compressor.
<b>E38</b>	The evaporator TL temperature is too low during startup	System shutdown, fault reported	Check TL liquid coil temp sensor, and outdoor PCB.
<b>E39</b>	Unit operating ambient temperature protection	Compressor shutdown, electric heating operation, fault reported.	Normal protection
<b>E44</b>	Power module communication failure		Check the power module board and connection line
<b>E50</b>	WiFi module communication failure		Check the WiFi module board and connecting line

<b>X01</b>	AC current limiting frequency		Normal protection
<b>X02</b>	T3 coil temp limiting frequency		Normal protection
<b>X03</b>	Tp exhaust gas temp limiting frequency		Normal protection
<b>X04</b>	Compressor current limiting frequency		Normal protection
<b>X05</b>	IPM temp limiting frequency		Normal protection

## 8. MAINTENANCE AND INSPECTION

- ✧ Check the water supply device and release often. You should avoid the condition of no water or air entering into system, as this will influence unit's performance and reliability. You should clear the pool/spa filter regularly to avoid damage to the unit as a result of the dirty or clogged filter.
- ✧ The area around the unit should be dry, clean and well ventilated. Clean the side heating exchanger regularly to maintain good heat exchange as conserve energy .
- ✧ The operation pressure of the refrigerant system should only be serviced by a certified technician .
- ✧ Check the power supply and cable connection often. Should the unit begin to operate abnormally, switch it off and contact the qualified technician.
- ✧ Discharge all water in the water pump and water system , so that freezing of the water in the pump or water system does not occur. You should discharge the water at the bottom of water pump if the unit will not be used for an extended period of time. You should check the unit thoroughly and fill the system with water fully before using it for the first time.
- ✧ Checks to the area  
Prior to beginning work on systems containing flammable refrigerants, safety checks are necessary to ensure that the risk of ignition is minimised.
- ✧ Work procedure  
Work shall be undertaken under a controlled procedure so as to minimise the risk of a flammable gas or vapour being present while the work is being performed.
- ✧ General work area  
All maintenance staff and others working in the local area shall be instructed on the nature of work being carried out. Work in confined spaces shall be avoided. The area around the workspace shall be sectioned off. Ensure that the conditions within the area have been made safe by control of flammable material.
- ✧ Checking for presence of refrigerant  
The area shall be checked with an appropriate refrigerant detector prior to and during work, to ensure the technician is aware of potentially flammable atmospheres. Ensure that the leak detection equipment being used is suitable for use with flammable refrigerants, i.e. non-sparking, adequately sealed or intrinsically safe.
- ✧ Presence of fire extinguisher  
If any hot work is to be conducted on the refrigeration equipment or any associated parts, appropriate fire extinguishing equipment shall be available to hand. Have a dry powder or CO2 fire extinguisher adjacent to the charging area.
- ✧ No ignition sources  
No person carrying out work in relation to a refrigeration system which involves exposing any pipework that contains or has contained flammable refrigerant shall use any sources of ignition in such a manner that it may lead to the risk of fire or explosion. All possible ignition sources, including cigarette smoking, should

be kept sufficiently far away from the site of installation, repairing, removing and disposal, during which flammable refrigerant can possibly be released to the surrounding space. Prior to work taking place, the area around the equipment is to be surveyed to make sure that there are no flammable hazards or ignition risks. "No Smoking" signs shall be displayed.

✧ Ventilated area

Ensure that the area is in the open or that it is adequately ventilated before breaking into the system or conducting any hot work. A degree of ventilation shall continue during the period that the work is carried out. The ventilation should safely disperse any released refrigerant and preferably expel it externally into the atmosphere.

✧ Checks to the refrigeration equipment

Where electrical components are being changed, they shall be fit for the purpose and to the correct specification. At all times the manufacturer's maintenance and service guidelines shall be followed. If in doubt, please consult the manufacturer's technical department for assistance.

The following checks shall be applied to installations using flammable refrigerants:

- a. The charge size is in accordance with the room size within which the refrigerant containing parts are installed.
- b. The ventilation machinery and outlets are operating adequately and are not obstructed.
- c. Marking to the equipment continues to be visible and legible. Markings and signs that are illegible shall be corrected.
- d. Refrigeration pipe or components are installed in a position where they are unlikely to be exposed to any substance which may corrode refrigerant containing components, unless the components are constructed of materials which are inherently resistant to being corroded or are suitably protected against being so corroded.

✧ Checks to electrical devices

Repair and maintenance to electrical components shall include initial safety checks and component inspection procedures. If a fault exists that could compromise safety, then no electrical supply shall be connected to the circuit until it is satisfactorily dealt with. If the fault cannot be corrected immediately but it is necessary to continue operation, an adequate temporary solution shall be used. This shall be reported to the owner of the equipment so all parties are advised.

Initial safety checks shall include:

- . That capacitors are discharged: this shall be done in a safe manner to avoid possibility of sparking.
- . That there no live electrical components and wiring are exposed while charging, recovering or purging the system.
- . That there is continuity of earth bonding.

✧ Repairs to sealed components

- 1) During repairs to sealed components, all electrical supplies shall be disconnected from the equipment being worked upon prior to any removal of sealed covers, etc. If it is absolutely necessary to have an electrical supply to equipment during servicing, then a permanently operating form of leak detection shall be located at the most critical point to warn of a potentially hazardous situation.
- 2) Particular attention shall be paid to the following to ensure that by working on electrical components, the casing is not altered in such a way that the level of protection is affected.

This shall include damage to cables, excessive number of connections, terminals not made to original specification, damage to seals, incorrect fitting of glands, etc.

Ensure that apparatus is mounted securely.

Ensure that seals or sealing materials have not degraded such that they no longer serve the purpose of preventing the ingress of flammable atmospheres. Replacement parts shall be in accordance with the manufacturer's specifications.

**NOTE:** The use of silicon sealant may inhibit the effectiveness of some types of leak detection equipment.

✧ Repair to intrinsically safe components

Do not apply any permanent inductive or capacitance loads to the circuit without ensuring that this will not exceed the permissible voltage and current permitted for the equipment in use.

Intrinsically safe components are the only types that can be worked on while live in the presence of a flammable atmosphere. The test apparatus shall be at the correct rating.

Replace components only with parts specified by the manufacturer. Other parts may result in the ignition of refrigerant in the atmosphere from a leak.

✧ Cabling

Check that cabling will not be subject to wear, corrosion, excessive pressure, vibration, sharp edges or any other adverse environmental effects. The check shall also take into account the effects of aging or continual vibration from sources such as compressors or fans.

✧ Detection of flammable refrigerants

Under no circumstances shall potential sources of ignition be used in the searching for or detection of refrigerant leaks. A halide torch (or any other detector using a naked flame) shall not be used.

✧ Leak detection methods

The following leak detection methods are deemed acceptable for systems containing flammable refrigerants.

Electronic leak detectors shall be used to detect flammable refrigerants, but the sensitivity may not be adequate, or may need re-calibration. (Detection equipment shall be calibrated in a refrigerant-free



area.) . Ensure that the detector is not a potential source of ignition and is suitable for the refrigerant used. Leak detection equipment shall be calibrated to the refrigerant employed and the appropriate percentage of gas (25 % maximum) is confirmed.

Leak detection fluids are suitable for use with most refrigerants but the use of detergents containing chlorine shall be avoided as the chlorine may react with the refrigerant and corrode the copper pipe-work.

If a leak is suspected, all naked flames shall be removed/ extinguished.

If a leakage of refrigerant is found which requires brazing, all of the refrigerant shall be recovered from the system, or isolated (by means of shut off valves) in a part of the system remote from the leak. Oxygen free nitrogen (OFN) shall then be purged through the system both before and during the brazing process.

✧ Removal and evacuation

When breaking into the refrigerant circuit to make repairs or for any other purpose. Conventional procedures shall be used. However, it is important that best practice is followed since flammability is a consideration. The following procedure shall be adhered to:

- . Remove refrigerant
- . Purge the circuit with inert gas
- . Evacuate
- . Purge again with inert gas
- . Open the circuit by cutting or brazing

The refrigerant charge shall be recovered into the correct recovery cylinders. The system shall be "flushed" with OFN to render the unit safe. This process may need to be repeated several times. Compressed air or oxygen shall not be used for this task.

Flushing shall be achieved by breaking the vacuum in the system with OFN and continuing to fill until the working pressure is achieved, then venting to atmosphere, and finally pulling down to a vacuum. This process shall be repeated until no refrigerant is within the system.

When the final OFN charge is used, the system shall be vented down to atmospheric pressure to enable work to take place. This operation is absolutely vital if brazing operations on the pipe-work are to take place.

Ensure that the outlet for the vacuum pump is not close to any ignition sources and there is ventilation available working on them.

✧ Labelling

Equipment shall be labelled stating that it has been de-commissioned and emptied of refrigerant. The label shall be dated and signed. Ensure that there are labels on the equipment stating the equipment contains flammable refrigerant.

✧ Recovery

When removing refrigerant from a system, either for servicing or decommissioning, it is recommended good practice that all refrigerants are removed safely.

When transferring refrigerant into cylinders, ensure that only appropriate refrigerant recovery cylinders are employed. Ensure that the correct number of cylinders for holding the total system charge is available. All cylinders to be used are designated for the recovered refrigerant and labelled for that refrigerant (i.e. special cylinders for the recovery of refrigerant). Cylinders shall be complete with pressure relief valve and associated shutoff valves in good working order. Empty recovery cylinders are evacuated and, if possible, cooled before recovery occurs.

The recovery equipment shall be in good working order with a set of instructions concerning the equipment that is at hand and shall be suitable for the recovery of flammable refrigerants. In addition, a set of calibrated weighing scales shall be available and in good working order. Hoses shall be complete with leak-free disconnect couplings and in good condition. Before using the recovery machine, check that it is in satisfactory working order, has been properly maintained and that any associated electrical components are sealed to prevent ignition in the event of a refrigerant release. Consult manufacturer if in doubt.

The recovered refrigerant shall be returned to the refrigerant supplier in the correct recovery cylinder, and the relevant Waste Transfer Note arranged. Do not mix refrigerants in recovery units and especially not in cylinders.

If compressors or compressor oils are to be removed, ensure that they have been evacuated to an acceptable level to make certain that flammable refrigerant does not remain within the lubricant. The evacuation process shall be carried out prior to returning the compressor to the suppliers. Only electric heating to the compressor body shall be employed to accelerate this process. When oil is drained from a system, it shall be carried out safely.

✧ Decommissioning

Before carrying out this procedure, it is essential that the technician is completely familiar with the equipment and all its detail. It is recommended good practice that all refrigerants are recovered safely. Prior to the task being carried out, an oil and refrigerant sample shall be taken in case analysis which is required prior to re-use of reclaimed refrigerant. It is essential that electrical power is available before the task is commenced.

a) Become familiar with the equipment and its operation.

b) Isolate system electrically.

c) Before attempting the procedure ensure that:

. Mechanical handling equipment is available, if required, for handling refrigerant cylinders.

. All personal protective equipment is available and being used correctly.

. The recovery process is supervised at all times by a competent person.

. Recovery equipment and cylinders conform to the appropriate standards.

d) Pump down refrigerant system, if possible.

e) If a vacuum is not possible, make a manifold so that refrigerant can be removed from various parts of the system.

f) Make sure that cylinder is situated on the scales before recovery takes place.

g) Start the recovery machine and operate in accordance with manufacturer's instructions.

h) Do not overfill cylinders. (No more than 80 % volume liquid charge).

i) Do not exceed the maximum working pressure of the cylinder, even temporarily.

j) When the cylinders have been filled correctly and the process completed, make sure that the cylinders and the equipment are removed from site promptly and all isolation valves on the equipment are closed off.

k) Recovered refrigerant shall not be charged into another refrigeration system unless it has been cleaned and checked.

#### ✧ Charging procedures

In addition to conventional charging procedures, the following requirements shall be followed.

-Ensure that contamination of different refrigerants does not occur when using charging equipment. Hoses or lines shall be as short as possible to minimise the amount of refrigerant contained in them.

-Cylinders shall be kept upright.

-Ensure that the refrigeration system is earthed prior to charging the system with refrigerant.

-Label the system when charging is complete (if not already).

-Extreme care shall be taken not to overfill the refrigeration system.

Prior to recharging the system it shall be pressure tested with OFN. The system shall be leak tested on completion of charging but prior to commissioning. A follow up leak test shall be carried out prior to leaving the site.

## 9. WIRING DIAGRAMS

Please refer to the wiring diagram on the electric box.

**Models: Remora Professional 8, Remora Professional 10, Remora Professional 14, Remora Professional 19, Remora Professional 25**

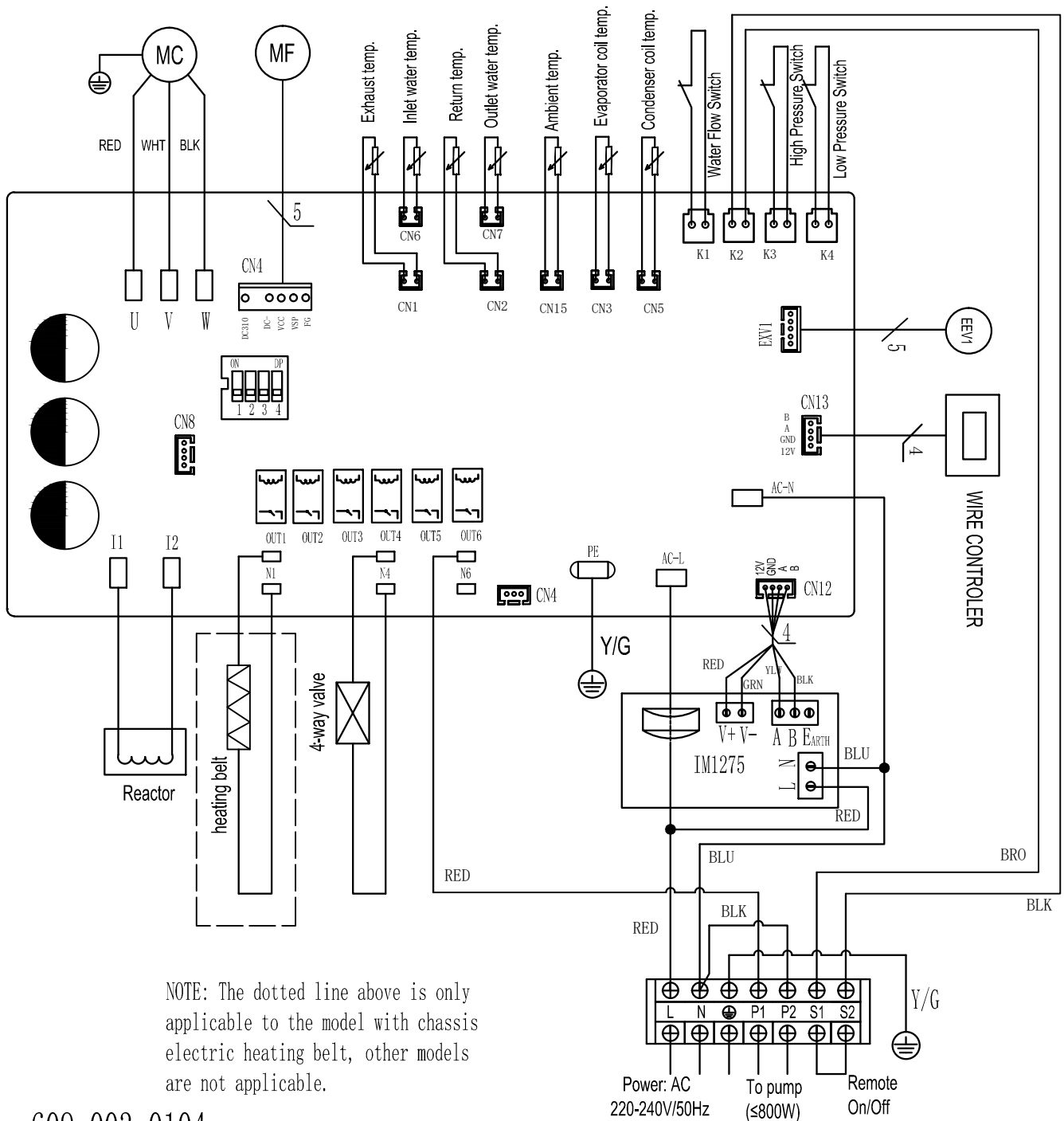

NOTE: The dotted line above is only applicable to the model with chassis electric heating belt, other models are not applicable.

609.003.0104

**Models: Remora Professional 35**

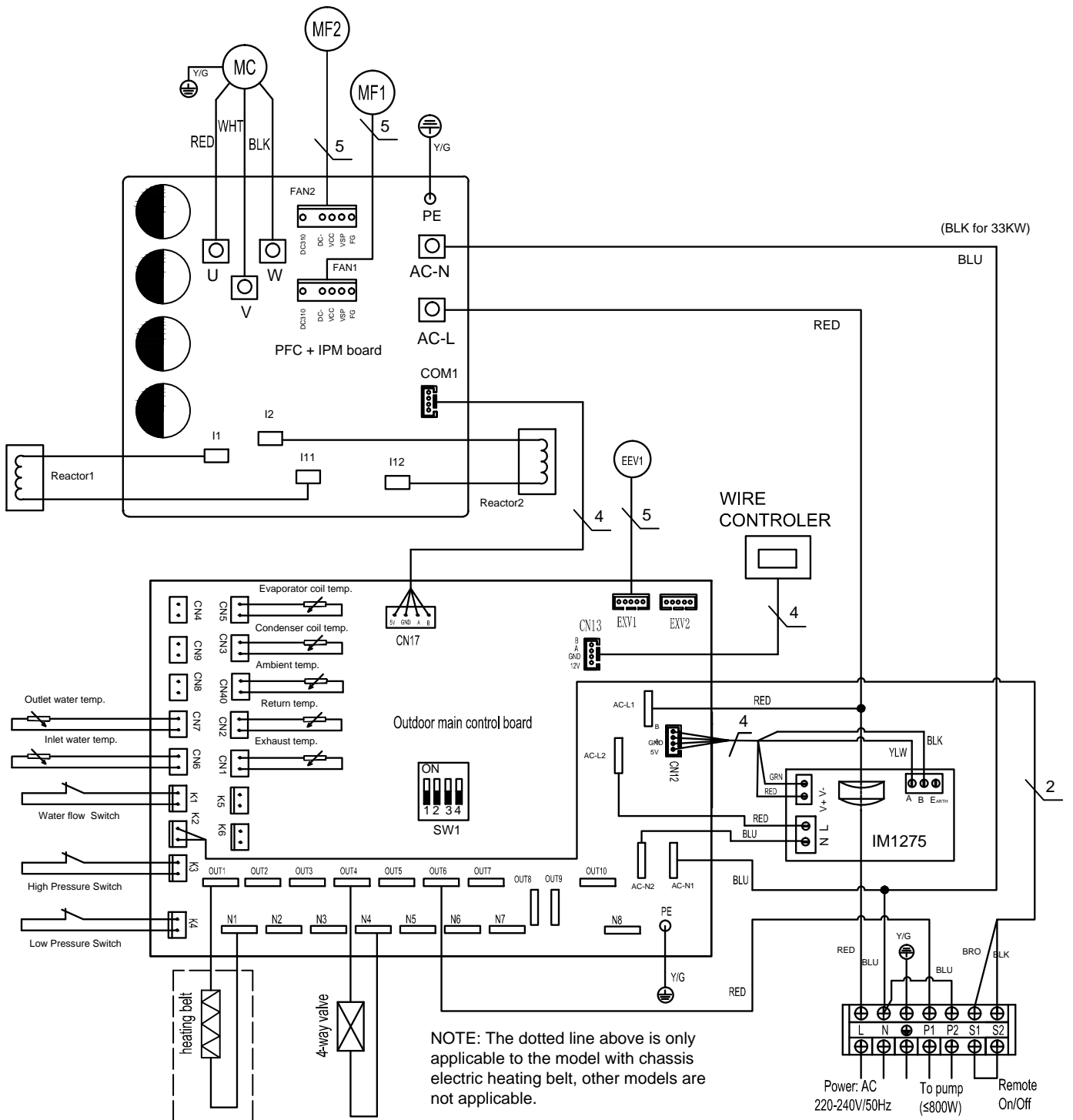

609.003.0117

## 10. CABLE SPECIFICATION

The Electrical supply must correspond to that indicated on the appliance. All supply cables have to be sized according to the appliance power and installation requirements.

Please refer to table below:

<b>Heat Pump Model</b>	<b>Cable Size</b>
<b>Remora Professional 8, Remora Professional 10</b>	3 x 2.0mm <sup>2</sup>
<b>Remora Professional 14</b>	3 x 2.5mm <sup>2</sup>
<b>Remora Professional 19, Remora Professional 25</b>	3 x 4.0mm <sup>2</sup>
<b>Remora Professional 35</b>	3 x 6.0mm <sup>2</sup>

The above are for references only. Please refer to qualified electricians if in doubt.

## 11. WIFI / APP APPLICATION

11.1 Please scan QR code below to download and install the APP.

①



②

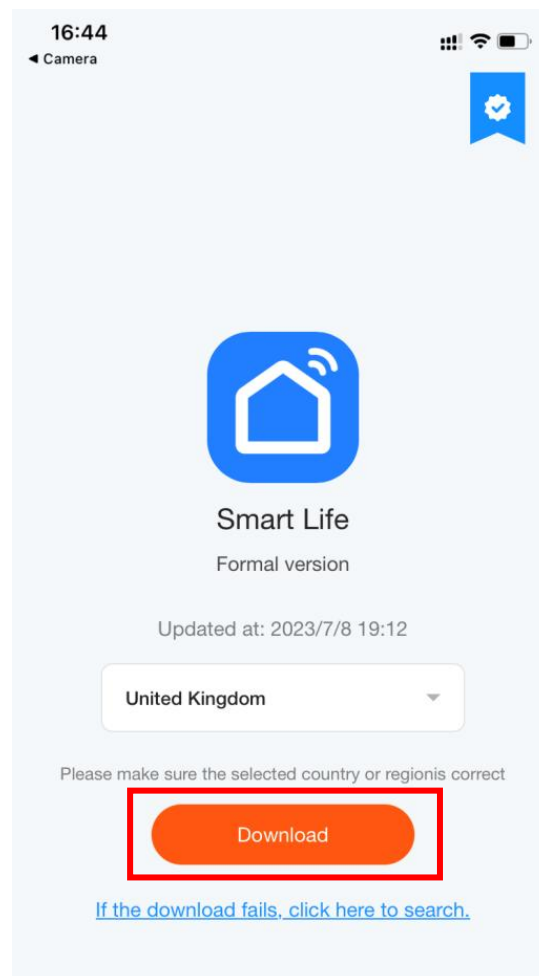

**11.2 After installation completed, please run the APP to do Register Step below.**

①

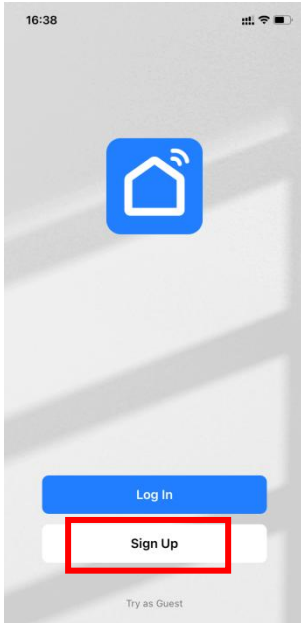

②

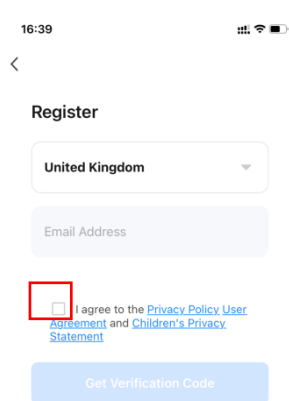

③

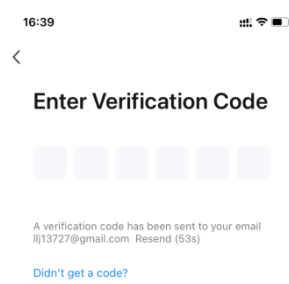

④

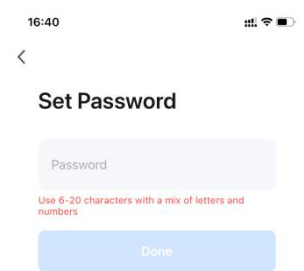



### 11.3 Please log in with your Register ID.

①

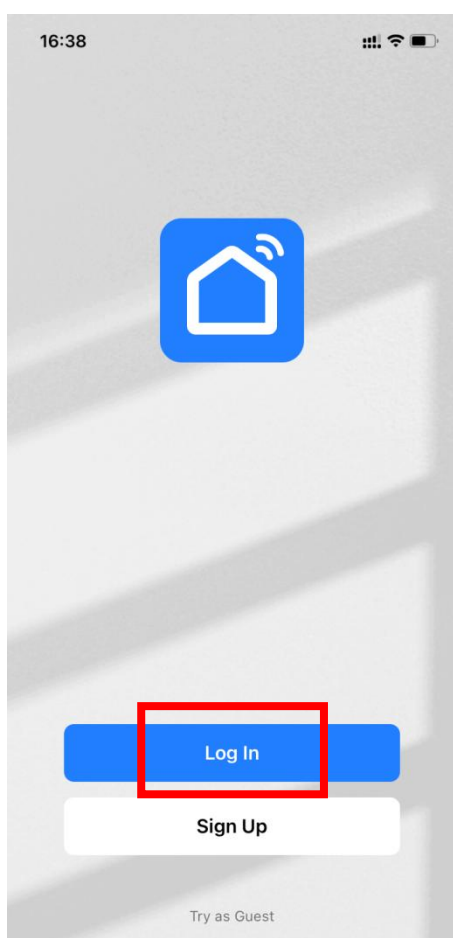

②

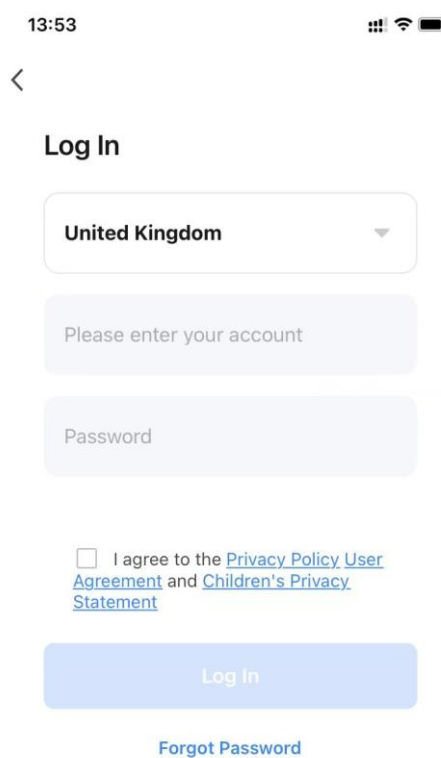

## 11.4 WIFI Pairing Mode

Please turn on the LCD controller to run WIFI Paring Mode.

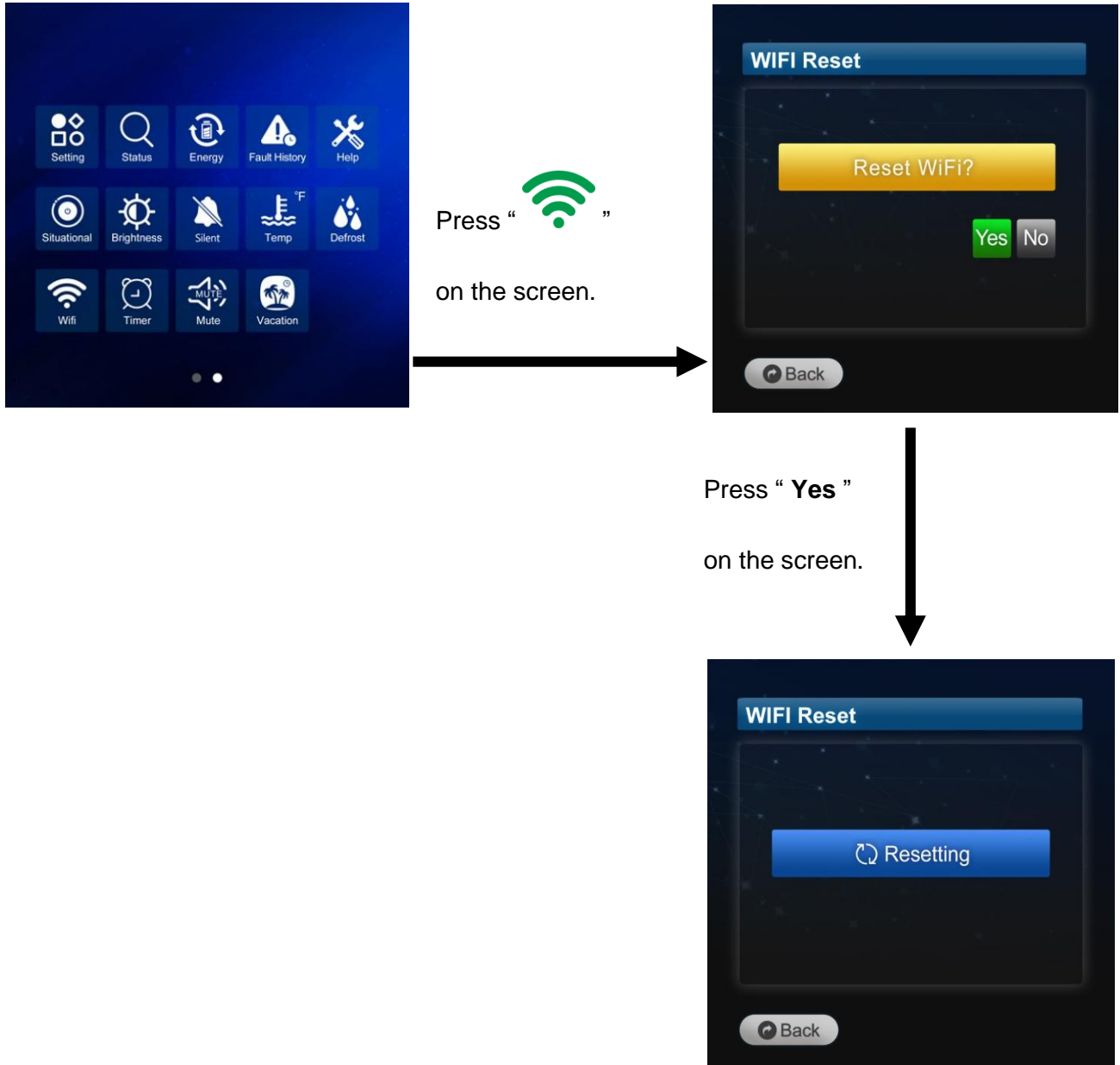

11.5 In the APP interface, please click “ + ” and select “ Add Device ”.

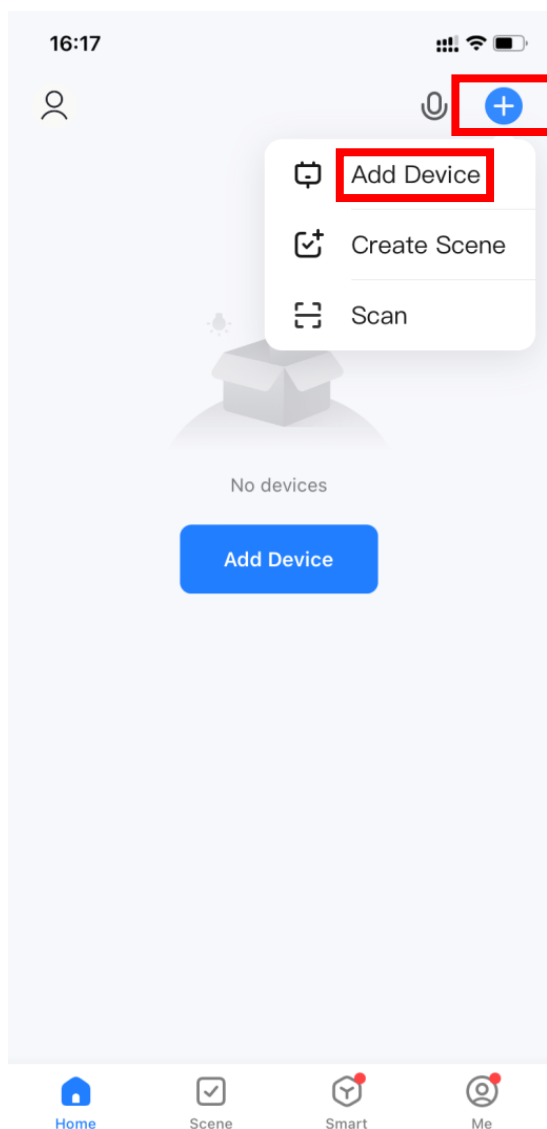

### 11.6 Input the WIFI ID and Password to search for devices.

①

②

(\*REMINDER: PLEASE SELECT 2.4 GHz NETWORK.)

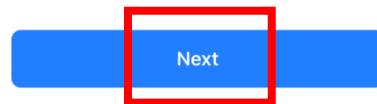
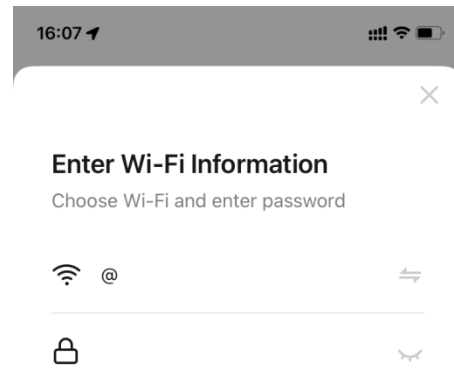
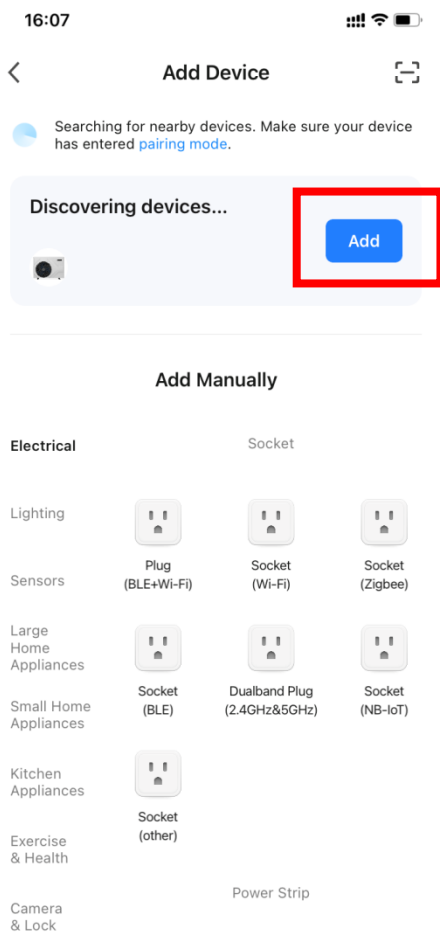

### 11.7 Add and connect to the device.

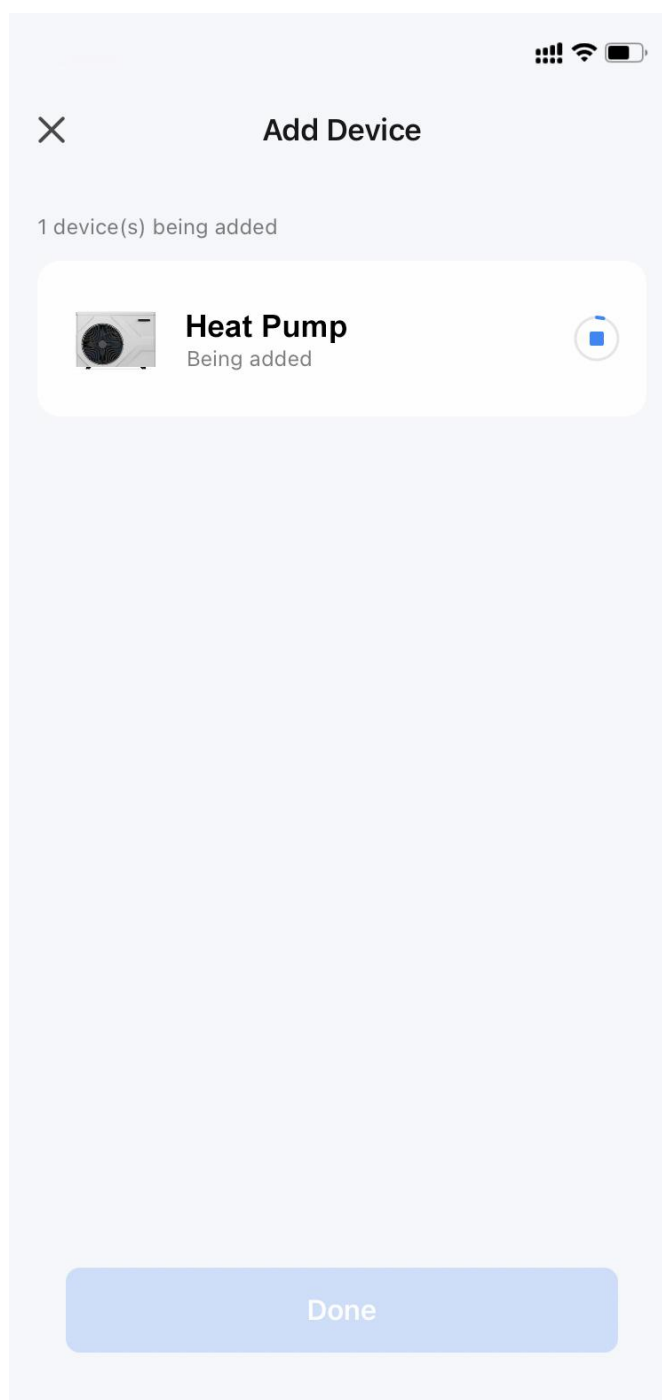

### 11.8 Operation Interface after successful connection.

